

# RCS

Hydraulic load indication for forklift trucks

## BENEFITS

- Attractively priced forklift scale
- Easy installation via T-coupling
- Indicator with 4 AA-batteries
- Suitable for rough applications
- For shipping weights and avoiding overloads



Top quality  
Easy to install

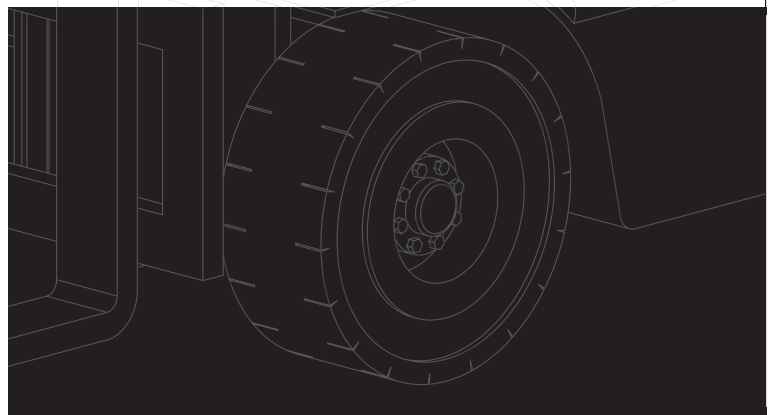

# RAVAS

## FUNCTIONS

- Automatic and manual zero correction
- Gross/net weighing
- Automatic tare and manual tare weight entry
- Totalling of weights above 200 kg, with sequence number
- Error messages in display
- Overload protection 300%

## HOW RCS WORKS

The operator picks up a load and lifts it until just past the marked reference height. He then lowers it gently to the reference point and stops there. The 2100 indicator calculates the weight and after about 3 seconds shows it fixed in the display.

## SYSTEM PACKAGE

- Weighing sensor
- Sealing ring
- Indicator 2100 with 4 AA-batteries and mounting bracket
- Lifting height reference mark stickers
- Mounting- and calibration instructions
- Operator manual

## STANDARD SPECIFICATIONS

- Capacity to fit the capacity of the truck (2,500, 5,000 or 10,000 kg)
- Graduation
  - 10 kg at 2,500 kg capacity
  - 20 kg at 5,000 kg capacity
  - 50 kg at 10,000 kg capacity
- System tolerance 2% of system capacity (see table on the right)
- Protection IP65
- Indicator LCD, 18 mm high digits
- Controls 3 function keys, on/off button
- Power supply 6Vdc from 4 AA-batteries
- Battery life 1 year, when used normally
- Auto shut-off after 3 minutes of non-use

## WEIGHING TOLERANCES

### LIFTING CAPACITY

1,200 kg  
1,600 kg  
2,000 kg  
2,500 kg  
3,000 kg  
4,500 kg  
7,500 kg  
10,000 kg

### MAXIMUM TOLERANCE \*

50 kg  
50 kg  
50 kg  
50 kg  
100 kg  
100 kg  
200 kg  
200 kg

\* Tolerance may occur above or below the weight on the display.



## PREMIUM OPTIONS\*

- 12V power supply from truck battery
- Converter 80/48/36/24Vdc - 12Vdc
- Thermal or matrix printer in separate housing (only on 12V version, prints weights above 200 kg)

## RAVAS Europe B.V.

P.O. Box 2023, NL-5300 CA Zaltbommel, The Netherlands  
T. +31 (0)418 51 52 20, F. +31 (0)418-51 53 20  
backoffice@ravas.com, www.ravas.com

# RAVAS